



Department of Planning and Zoning
Town of Vienna, Virginia
 127 Center Street South
 Vienna, VA 22180
 Phone: (703) 255-6341
 Email: DPZ@viennava.gov

Project Overview

#1630322

Project Title: Aroma Express**Jurisdiction:** Town of Vienna**Application Type:** Board of Architectural Review: Signs**State:** VA**Workflow:** 1. Initial Review**County:** Fairfax

Project Contacts

Contact Information: Applicant

Heejin Chang
 Creation Sign LLC
 7364 McWhorter PI
 Annandale, VA 22003
 P:7036225958
creationsignco@gmail.com

Contact Information: Owner

Tina Chenosky
 Key Point Partners
 4201 Mitchellville Rd, 501
 Bowie, MD 20716
 P:3014641195
tchenosky@keypointpartners.com

Indicate which of the following additional project contacts are to be included on project correspondences.: Contractor

Project Address

Project Address: 416 MAPLE AVE E**Suite:****Parcel (PIN): Address/Parcel****Town Limits: Address/Parcel**

- 416 MAPLE AVE E: 0382 02 0017B

- 416 MAPLE AVE E: IN TOWN OF VIENNA

Current Zoning: Address/Parcel

- 416 MAPLE AVE E: C-1

Project Description

Project Description:

Installation of wall mount signage, awning fabric replacement and monument sign face replacement.

Fairfax County Building Permit Number(s): 25TMP-023491

Project Information

Business/Development Name: Aroma Express**Width of Building Frontage/Leased Area:** 22.5**Total Allowable Building Sign Area:** 45**Are any Fairfax County Building Permit application numbers associated with this application?:** Yes**Fairfax County Building Permit Number(s):** 25TMP-023491**BAR Agenda Item:**

1. Installation of non illuminated wall mount sign.
2. Awning fabric replacement with new lettering (Bakery, Coffee, Wine)

BAR Meeting Date: 03/20/2025

Project File Number: 0

Project Information

Total Number of Signs Proposed: 3

Sign Type A (please provide all applicable details below) ✕

Proposed Sign Type: Front Facade

Scope of Work: New

Description of Sign:

Sign Area Height: 3

Non illuminated dimensional metal letters on a printed backboard.

Sign Area Width: 11.25

Total Sign Face Area: 33.75

Sign Depth: 3.5

Window Height:

Window Width:

Total Window Area:

Awning Depth:

Awning Width:

Height from Bottom to Sidewalk:

Total Structure Height:

Illumination Type: None

Lumens:

Kelvins:

Alternative Measurement:

Sign Type B (please provide all applicable details below) ✕

Proposed Sign Type: Awning

Scope of Work: Reface

Description of Sign:

Sign Area Height: .416

Awing fabric replacement with new lettering

Sign Area Width: 10

Total Sign Face Area: 4.16

Sign Depth:

Window Height:

Window Width:

Total Window Area:

Awning Depth: 3

Awning Width: 18.75

Height from Bottom to Sidewalk: 10

Total Structure Height:

Illumination Type: None

Lumens:

Kelvins:

Alternative Measurement:

Sign Type C (please provide all applicable details below) ✕

Proposed Sign Type: Monument

Scope of Work: Reface

Description of Sign:

Sign Area Height: 2.83

Acrylic sign face with printed graphic.

Sign Area Width: 3.5

Total Sign Face Area: 9.9

Sign Depth: .125

Window Height:

Window Width:

Total Window Area:

Awning Depth:

Awning Width:

Height from Bottom to Sidewalk:

Total Structure Height: 8

Illumination Type: None

Lumens:

Kelvins:

Alternative Measurement:

Sign Type D (please provide all applicable details below) ✕

Proposed Sign Type:

Description of Sign:

Sign Area Width:

Sign Depth:

Window Width:

Awning Depth:

Height from Bottom to Sidewalk:

Illumination Type:

Kelvins:

Scope of Work:

Sign Area Height:

Total Sign Face Area:

Window Height:

Total Window Area:

Awning Width:

Total Structure Height:

Lumens:

Alternative Measurement:



Department of Planning and Zoning

Town of Vienna, Virginia

127 Center Street S

Vienna, Virginia 22180

Phone: 703-255-6341 | Email: DPZ@viennava.gov

Hours: Monday – Friday, 8:00 am - 4:30 pm

APPLICANT AUTHORIZATION FORM

I hereby certify that I am the property owner or I have authority of the property owner to make this application, that the information is complete, and that if a permit or certificate is issued, the construction and/or use will conform to the zoning ordinance and other applicable laws and regulations including private building restrictions, if any, which relate to the property. This form must be submitted prior to issuance of any permit or certificate.

I understand that the permits or certificates obtained pursuant to this permit authorization form will be in my name. I accept full responsibility for the work performed.

Check one box below:

I am the property owner

I am an applicant who has the authority of the property owner (owner will still need to sign)

Description of permits or certificates being applied for:

at the following address: 416 Maple Ave E. Vienna VA 22180

Applicant Name (fill out if owner is not applicant): Heejin Chang

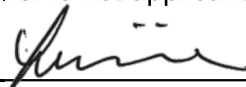
Signature of Applicant:  Date: 2-18-2025

Property Owner's Name: JDC Vienna Garden, LLC

Signature of Property Owner:  Date: 2/19/25
Managing Member of JDC Vienna Garden, LLC

4201 Mitchellville Road
Suite 501
Bowie, MD 20716
Tel: 301.464.1195
Fax: 301.464.1197
KeyPointPartners.com

February 18, 2025

SENT VIA EMAIL ONLY

Mr. German Noriega
Aroma Café Vienna, LLC
4608 Easterlin Way
Woodbridge, VA 22192
german@aroma-cafe.co

Reference: Aroma Cafe - Vienna Crossing
Signage Approval Letter

Dear Mr. Noriega,

Landlord's architect has reviewed your sign submittal prepared by Creation Sign, LLC for the above referenced project located at 416 Maple Avenue East, Vienna, VA 22181. Landlord approves the signage as noted on the attached.

Tenant is fully responsible for compliance with the local Zoning Ordinance for compliance with all regulations pertaining to the size, locations and all other provisions pertaining to signage and securing all the necessary permits prior to installation. The proposed signage will need to be approved by the Town of Vienna Board of Architectural Review (BAR) and any other jurisdiction having authority.

Please feel free to contact me with any questions.

Sincerely,

Tina R. Chenosky

Tina R. Chenosky, CRRP
Senior Property Manager
As Agent for JDC Vienna Crossing, LLC

cc: creationsignco@gmail.com
Tenant File

Attachment

Non-Illuminated Metal Letters on Fabricated Backboard

REVIEWED
By JOHN at 2:20:31 PM, 2/13/2025
SIGN DETAIL

Sign Type: Outdoor Use **Total Allowable Sign area 2 feet for every linear foot per Article 2 of Code of the Town of Vienna or 45 s.f. permitted**



FRONTAGE = 22'-6"
SQ.FT. = 33.75 sq.ft.
SCALE: 3/8" = 1'-0"

- Print and Wrapped Aluminum backer
- Brushed Gold finish
- Stainless Steel Face & Return

Sign Area 33.73 s.f. 11'-3"
Total Proposed Sign Area with Awning 37.95 +- (OK- less than a 45 s.f.)

May need to lower sign a few inches to create a require a border space per the Town Code



Store Front 22'-6"

13'-0"
from ground to bottom of the sign

SIGN SPECS (materials & mounting details)

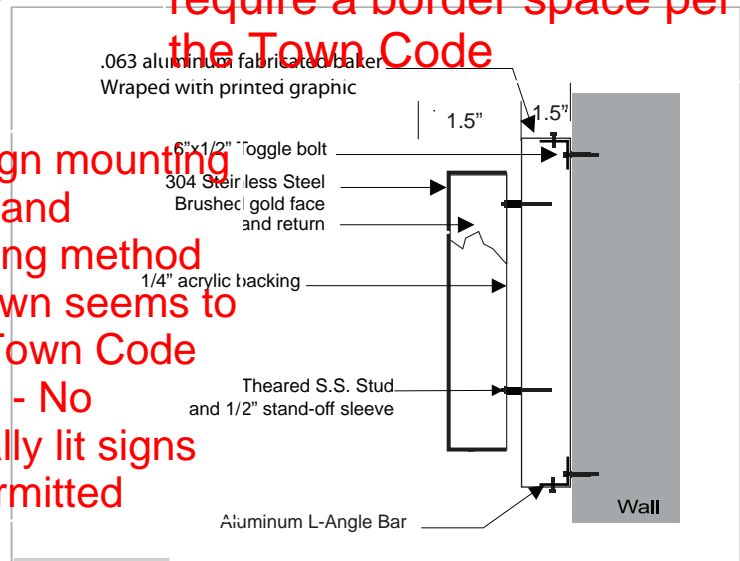

This sign mounting height and mounting method as shown seems to meet Town Code criteria - No internally lit signs are permitted

Scale: NTS

This sign is intended to be installed in accordance with the requirements Article 600 of the National Electrical Code and/or other applicable local code this includes proper grounding and bonding of the sign.

NOTE: PRINTED COLORS ARE NOT AN EXACT MATCH FOR MATERIAL COLORS

Creation Sign LLC.

4230 Lafayette Center Dr.
Suite O & P
Chantilly VA 20151

This is an original design submitted by Creation Sign LLC for your personal use. It is not to be shown to anyone outside your firm, nor is it to be used, copied reproduced, or exhibited to anyone. All or any part of this design (except registered trademarks) remain the property of Creation Sign LLC.

DRAWING # 250127AE-SI

Aroma Express

416 Maple Ave E.
Vienna VA 22180

Awning Fabric replacement

Estimated Sign Area on Awning
10 feet x 5" + 4.2 s.f.

BAKERY COFFEE WINE 5"

3'-8"

10"

18'-9"

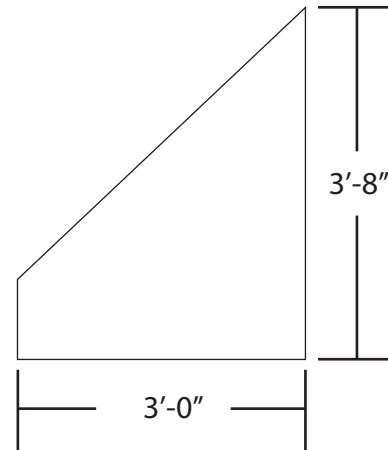

■ Sunbrella Awning
Color:TBD

■ SW 6396

NOTE: PRINTED COLORS ARE NOT AN EXACT MATCH FOR MATERIAL COLORS

Creation Sign LLC.

4230 Lafayette Center Dr.
Suite O & P
Chantilly VA 20151

This is an original design submitted by Creation Sign LLC for your personal use. It is not to be shown to anyone outside your firm, nor is it to be used, copied reproduced, or exhibited to anyone. All or any part of this design (except registered trademarks) remain the property of Creation Sign LLC.

DRAWING # 250127AE-SI

Aroma Express

416 Maple Ave E.
Vienna VA 22180

Monumnet sign face replacement

Proposed



Existing



NOTE: PRINTED COLORS ARE NOT AN EXACT MATCH FOR MATERIAL COLORS

Creation Sign LLC.
4230 Lafayette Center Dr.
Suite O & P
Chantilly VA 20151

This is an original design submitted by Creation Sign LLC for your personal use. It is not to be shown to anyone outside your firm, nor is it to be used, copied, reproduced, or exhibited to anyone. All or any part of this design (except registered trademarks) remain the property of Creation Sign LLC.

DRAWING # 250127AE-SI

Aroma Express
416 Maple Ave E.
Vienna VA 22180

Proposed



Existing



NOTE: PRINTED COLORS ARE NOT AN EXACT MATCH FOR MATERIAL COLORS

Creation Sign LLC.

4230 Lafayette Center Dr.
Suite O & P
Chantilly VA 20151

This is an original design submitted by Creation Sign LLC for your personal use. It is not to be shown to anyone outside your firm, nor is it to be used, copied reproduced, or exhibited to anyone. All or any part of this design (except registered trademarks) remain the property of Creation Sign LLC.

DRAWING # 250127AE-SI

Aroma Express

416 Maple Ave E.
Vienna VA 22180